

INNOVATION
2019

DYNAMIC hullvane

WE MASTER HYDRODYNAMICS

UP TO
25%
LESS FUEL
CONSUMPTION

UP TO
40%
LESS PITCHING
MOTION

A COLLABORATION OF HULL VANE BV AND NAIAD DYNAMICS

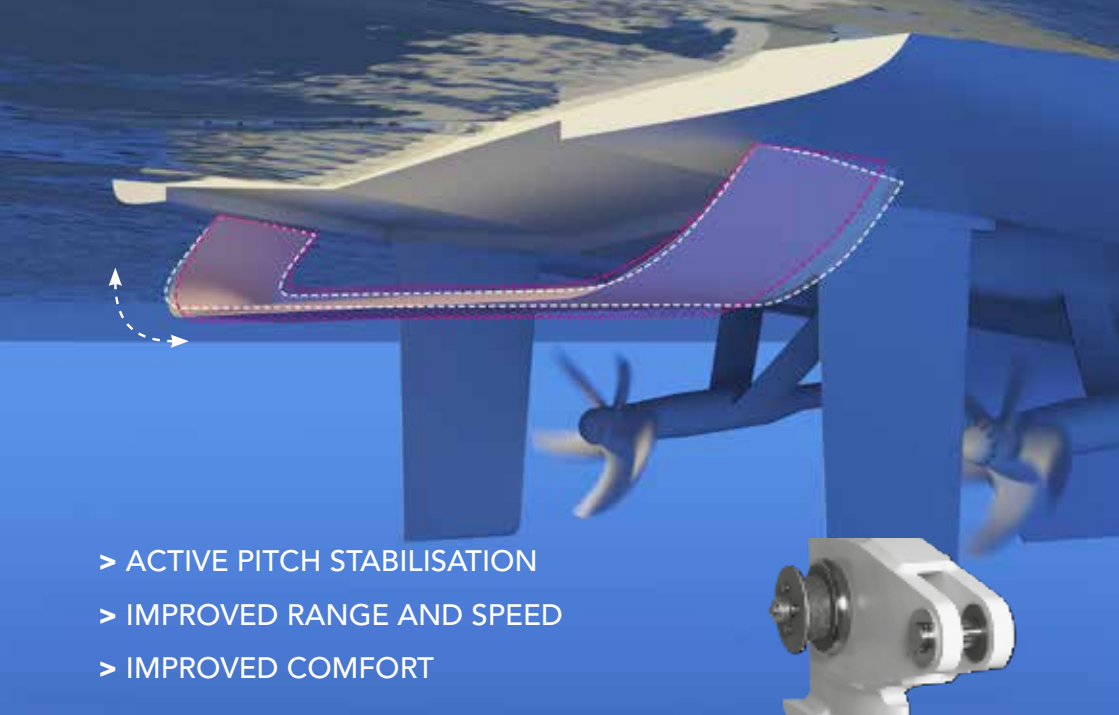

- > ACTIVE PITCH STABILISATION
- > IMPROVED RANGE AND SPEED
- > IMPROVED COMFORT

Why?

- > LESS VERTICAL ACCELERATIONS
- > LESS SEASICKNESS
- > LESS PROPULSION POWER
- > LESS NOISE

How?

- > PROVEN HYDRODYNAMICS
- > PROVEN CONTROL SYSTEM
- > CFD OPTIMISATION

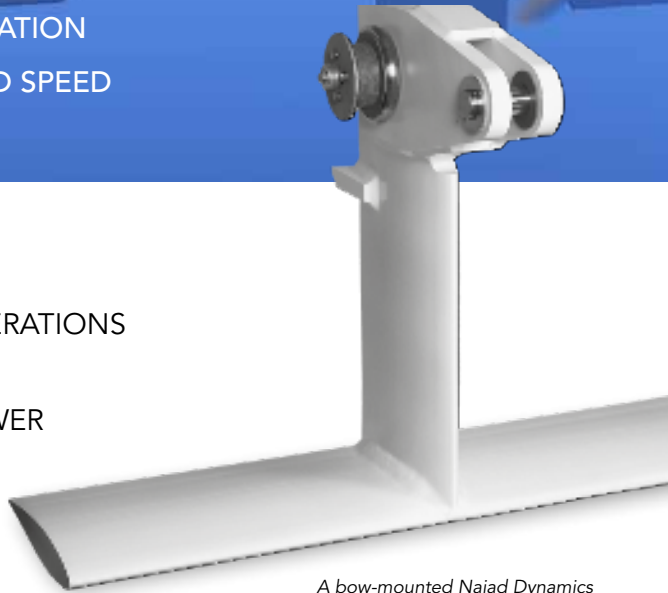

A bow-mounted Naiad Dynamics T-foil is shown, illustrating proven and very similar mechanical operation as the Dynamic Hull Vane®.

hullvane

NAIAD[®]
DYNAMICS

DYNAMIC
hullvane

A COLLABORATION OF HULL VANE BV AND NAIAD DYNAMICS

hullvane.com | naiad.com