

THE EFFECTS OF THE HULL VANE ON SHIP MOTIONS OF FERRIES AND ROPAX VESSELS

K Uithof, B Bouckaert, P G van Oossanen, and N Moerke, Hull Vane B.V., van Oossanen Naval Architecture, and van Oossanen Fluid Dynamics, NL

SUMMARY

This paper discusses research into the seakeeping aspects of the Hull Vane, a fixed hydrofoil that can be attached to the transom of a vessel which can significantly reduce the vessel's resistance. Earlier research on superyachts, offshore vessels and naval ships shows that the Hull Vane significantly reduces the pitch motion in waves, it contributes to the roll damping of vessels, and it improves the course keeping ability of vessels. This results in lower accelerations on board, in improved operability, and higher comfort levels for crew and passengers.

In this paper, the extent to which this is also valid on larger (RoPax) vessels is quantified. Results from tank tests of the 167 meter container vessel *Rijnborg* and CFD computations on the 167 meter RoPax vessel *Norbank* will be shown and discussed. These results show that both the pitch motion and the added resistance due to waves can also be effectively reduced by applying a Hull Vane on larger vessels.

1. INTRODUCTION

The patented Hull Vane is a fixed hydrofoil that can be attached to the transom of the vessel. It uses the upward flow at this location to recuperate some of the energy that otherwise would be lost in the transom wave.

This paper discusses research into the seakeeping aspects of the Hull Vane. Although on smaller vessels, like yachts, offshore vessels, and naval ships, much research has been done in the past, the influence of the Hull Vane on the seakeeping aspects of larger vessels has not been extensively investigated. Especially for passenger carrying vessels as ferries, RoPax vessels, or cruise ships, the seakeeping aspects are important. Not only the comfort of passengers is relevant, the operability is of uttermost importance for the line's income and image.

In this paper, the theoretical background of the Hull Vane will first be introduced, and in particular its influence on the vessel's performance in waves. Then, results of earlier research on superyachts, offshore vessels and naval ships will be briefly discussed. Subsequently, the tank tests on the 167m container vessel *Rijnborg* and the Computational Fluid Dynamics (CFD) computations on the 167m RoPax vessel *Norbank* will be elaborated upon. The paper is concluded with a discussion and a conclusion.

2. THEORETICAL BACKGROUND

Although the working principles of the Hull Vane have been extensively described in earlier work [1], a short recapitulation will be provided in this section.

The reduction in fuel consumption that the Hull Vane causes can be contributed to various factors. Placing the

foil in the inclined part of the transom wave creates a lift force which is tilted forward. Decomposing this force results in a resistance reducing force in x-direction, and a trim influencing force in z-direction, which also has its influence on the vessel's resistance. Furthermore, because the flow is redirected to a more horizontal direction, the transom wave is reduced.

The last effect, which is most important for the current work, is related to the foil's behaviour in waves. Moving a flat plate up and down is hindered by the water surrounding it. The same goes for the Hull Vane, when the vessel is pitching in waves. The Hull Vane is then forced up and down, and the resulting dampening effect of the water on the movement of the Hull Vane also dampens the pitching motion of the vessel. This not only results in lower accelerations on board of the vessel, it also lowers the added resistance due to waves.

3. PREVIOUS RESEARCH

3.1 MOTIONS AND RESISTANCE IN WAVES

Much (mostly unpublished) research is already put in substantiating the claims regarding the dampening of the pitching motion and the reduction of the added resistance.

The only published research on the Hull Vane's effect on seakeeping [2] was done for the 108m Holland Class Offshore Patrol Vessel (OPV). A number of CFD computations in regular waves were performed. It was demonstrated that the amplitude of the pitching motion was reduced by 8.2% in 2m waves and by 6.5% in 4m waves. The CFD computations also showed that the heave motion's amplitude was reduced by 2.4% and 3.1%, respectively. These reductions combined lead to a

13.1% and 11.7% reduction of the vertical accelerations at the aft deck (10% L_{WL}). Additionally, a 4.9% and 5.7% reduction of the added resistance was found.

In January 2012, tank tests were performed at the Wolfson Unit in the United Kingdom on the 42m motor yacht *Alive*, with and without Hull Vane. In 3 different wave conditions at 3 different speeds, the RMS of the pitch motion was on average 4.6% lower after the Hull Vane was fitted to the model.

Most other research has been done with the use of CFD. Due to the costs and time involved with time-dependent computations, solely computations in regular waves have been performed with and without Hull Vane. For statistical analysis of motions in waves, a minimum of 120 wave encounters is recommended, which would require long and costly computations. Computations in regular waves show results as soon as the signal has converged into a stable cycle.

The vessels that have been analysed in waves are a 18m motor yacht (MY), a 50m patrol vessel (PV), a 55m supply vessel (SV), an 88m supply vessel, and the aforementioned 108m offshore patrol vessel (OPV). The analysed wave heights (H_w) and wave periods (T_w) are displayed in Table 1, along with the results: The reduction of pitch response amplitude operator (RAO) dP , and reduction of added resistance dRA .

Vessel	Vs kn	Hw m	Tw s	dP -	dRA -
18m MY	14.0	0.5	4.00	-16.3%	-21.7%
18m MY	14.0	1.0	4.00	-12.4%	-8.8%
50m PV	20.0	1.0	5.66	-20.5%	-39.2%
55m SV	20.0	1.0	5.66	-14.4%	-29.3%
88m SV	15.0	1.5	7.00	-6.6%	-4.8%
88m SV	15.0	1.5	7.75	-5.3%	-5.3%
88m SV	15.0	1.5	8.50	-2.3%	-4.6%
108m OPV	17.5	2.0	8.00	-8.2%	-4.9%
108m OPV	17.5	4.0	8.00	-6.5%	-5.7%

Table 1: Found reductions of pitch RAO and added resistance due to waves for vessels analysed in the past.

It can be seen that Hull Vane decreases the vessel's motions in waves and consequently its added resistance. However, the analysed vessels are not alike ferries or RoPax vessels, in size and hull shape. Whether the effect of the Hull Vane is the same on these types and sizes of vessels is the subject of current research.

3.2 DAMPING OF ROLL MOTION

Part of the studies on the feasibility of the Hull Vane on the 108m OPV [2] were roll decay tests. Although the effect of the Hull Vane on the roll is less than in pitching,

the roll is dampened in a similar way as the pitch is dampened: if the vessel rolls, the Hull Vane is rotated, which is dampened by the water surrounding the Hull Vane. This reduces the roll motion of the vessel.

Two roll decay CFD computations were performed: at zero speed, and at 17.5 knots. For both cases, the roll damping coefficients were calculated with and without Hull Vane. The results showed that the damping coefficient was increased by 4.1% at zero speed, and by 11.4% at 17.5 knots.

It needs to be noted that the Holland-Class OPV's are equipped with fin stabilizers. It is therefore expected that the benefit of the Hull Vanes roll damping effect lies mainly in the reduction in power consumption of the stabilizers.

3.3 MANOEUVRABILITY

In 2014, a 55m Supply Vessel was launched with a Hull Vane. The sea trials for this vessel included manoeuvrability tests with and without Hull Vane. The average overshoot of the vessel was decreased from 3.5 degrees to 1.8 degrees during the zig-zag tests. The turning circle was increased from 313 to 326 meter. The conclusion that can be drawn from these tests is that the Hull Vane increased the directional stability of the vessel, which can be beneficial, e.g. in preventing broaching in stern-quartering waves. The drawback is that the directional stability reduces the manoeuvrability at speed slightly.

4. METHOD

4.1 TANK TESTS ON THE 167m CONTAINER VESSEL *RIJNBORG*

An 8m model ($\lambda = 21$) is used for seakeeping tests performed at MARIN in Wageningen, the Netherlands in 2007. The model is self-propelled and self-steered, and can be equipped with a Hull Vane. An overview of the aft of the model equipped with the Hull Vane and measurement equipment is provided in Figure 1.



Figure 1: Tank test setup with Hull Vane.

In earlier tests with the same model, the optimum angle and location of the Hull Vane was determined in order to reduce the vessel's resistance. During these tests in flat water, a resistance reduction of 10.1% was found at 17 knots, increasing to 15.5% at 21 knots.

The main objectives of the current model tests are to quantify whether the Hull Vane reduces the required thrust in waves, and to study the influence the device has on the seakeeping behaviour of the vessel.

For this purpose, decay tests (roll and pitch), and transit tests in waves (regular and irregular) have been done. An overview of the regular wave characteristics in which the vessel was tested with and without Hull Vane is provided in Table 2. For the wave conditions marked with an asterisk, only the model with Hull Vane was tested.

	V_s	H_w	ω	μ
	<i>kn</i>	<i>m</i>	<i>rad/s</i>	<i>deg</i>
001*	20	1.0	0.45	180
002	20	1.0	0.50	180
003	20	1.0	0.55	180
004	20	1.0	0.60	180
005	20	1.0	0.70	180
006*	20	1.0	0.90	180
007	20	2.0	0.55	180

Table 2: Wave characteristics for tank tests in regular waves.

The results of the vessel with and without Hull Vane will be compared for pitch, heave, and required thrust.

Additionally, the vessel with Hull Vane was tested in a range of irregular wave systems. These conditions include all wave directions, significant wave heights up to

7 meter, and ship speeds ranging between 5 and 20 knots. The goal of these tank tests is to see whether slamming on the Hull Vane would occur, and how severe these resulting slamming forces would be. The vessel was tested in full load and ballast load conditions, in which the Hull Vane is above the static waterline. The vessel was not tested in irregular waves without Hull Vane, as the occurrence of slamming was the main research goal.

4.2 CFD COMPUTATIONS ON THE 167m ROPAX VESSEL NORBANK

For the 167m RoPax vessel *Norbank*, first a Hull Vane optimisation routine in flat water is performed. In this optimisation process, the structural requirements as well as client-specific requirements were taken into account. This resulted in the Hull Vane position and geometry as displayed in Figure 2.

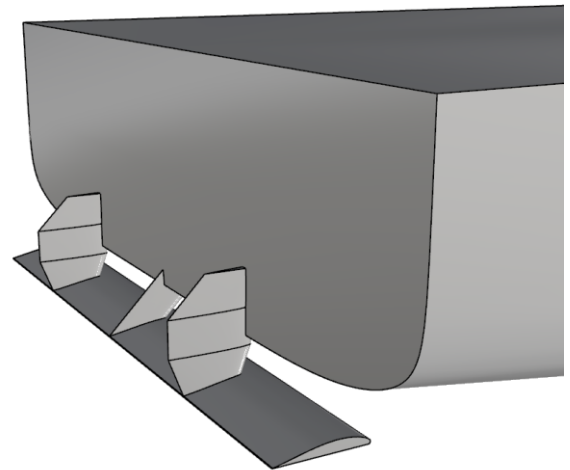

Figure 2: optimised Hull Vane geometry for the 167m *Norbank* RoPax vessel.

For the bare hull model without Hull Vane, the resistance in flat water at 20 knots was found to be 593 kN. With Hull Vane, the computed total resistance is 533 kN, which is a 10.1% resistance reduction.

For the CFD computations in waves, the struts were omitted from the model, with the purpose of reducing the amount of cells required to describe the model. The influence of the struts on the resistance is less than 1%, and the effect on the motions in head waves is assumed to be negligible: They improve the efficiency of the wing between the struts, cancelling out the influence of the struts itself.

To determine which wave to analyse the vessel in, strip theory based software for seakeeping analysis was used to find the wave period in which the response of the vessel is most severe. This resulted in a wave (encounter)

period of 6.28 seconds. A wave height of 2.5m was chosen to cover 87.5% of the waves recorded in the vessel's operating area [3].

The CFD code used is FINE/Marine, a RANS solver developed specifically for marine application by Numeca and the University of Nantes. An adaptive grid refinement routine was used to better capture the free surface, especially in the breaking waves around the vessel.

The results of the vessel with and without Hull Vane will be compared for pitch, heave, vertical accelerations and (added) resistance.

5. RESULTS

5.1 TANK TESTS ON THE 167m CONTAINER VESSEL RIJNBORG

5.1.1 Roll decay test

First of all, a roll decay test was performed in full load condition. The model was heeled to an angle and then released. The resulting roll motion is displayed graphically in Figure 3.

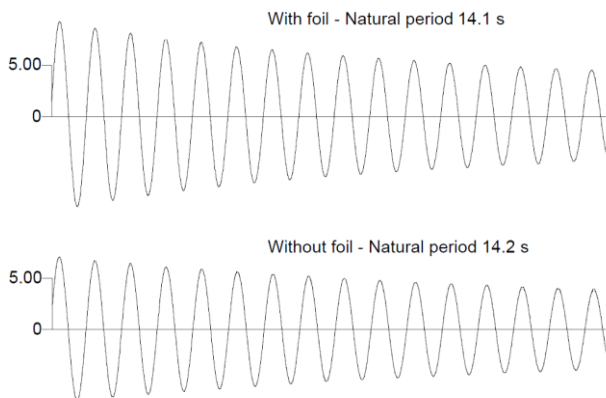

Figure 3: Roll decay signal for the *Rijnborg* with and without Hull Vane.

With the foil attached to the model, the natural period has gone down slightly, from 14.2 to 14.1 seconds. The logarithmic decrement of the motion has gone down from -0.0368 to -0.0434, which is 17.9% lower.

5.1.2 Pitch decay test

Subsequently, a pitch decay test was performed in full load condition. Equivalently to the roll decay test, the vessel was heeled to an angle and then released. The resulting pitch motion for the vessel with and without Hull Vane are displayed in Figure 4.

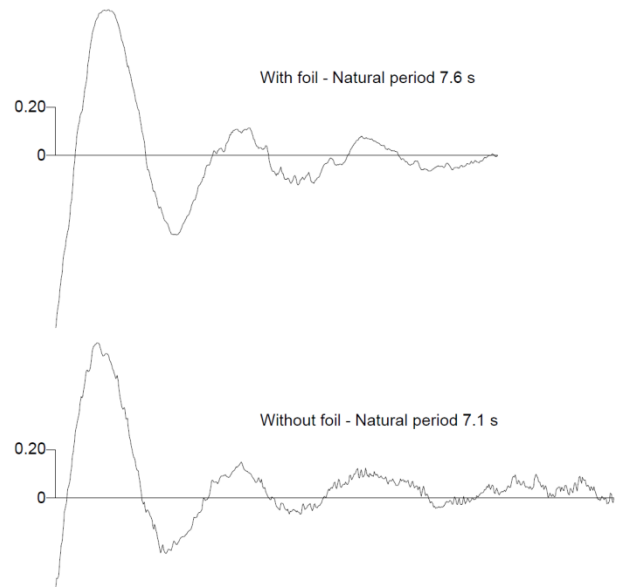

Figure 4: Pitch decay signal for the *Rijnborg* with and without Hull Vane.

With the foil attached to the model, the natural period has increased from 7.1 to 7.6 seconds. The motion was dampened too quickly to measure a reliable logarithmic decrement.

5.1.3 Tests in regular waves

The vessel with and without foil was exposed to regular head waves, and the required thrust from the propellers was measured, as well as the vessel's response to waves in terms of motions in all six degrees of freedom. All tests in regular waves have been performed in full load condition.

The RAO of the pitch motions for the tested wave frequencies is displayed in Figure 5, for both with and without Hull Vane.

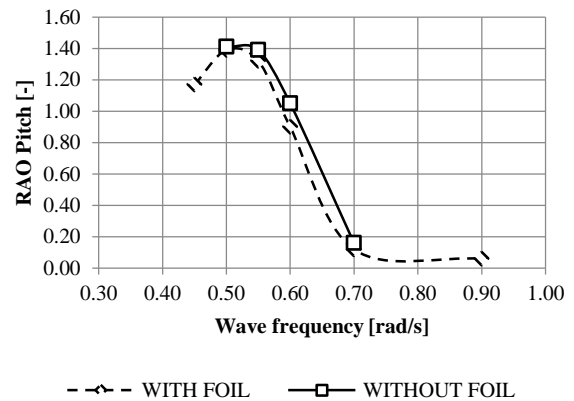

Figure 5: Pitch RAO for the *Rijnborg* in waves.

It can be seen that the pitch motion has been reduced by the addition of the Hull Vane to the model. The RAO has decreased in all tested wave conditions, on average by 11.4%. In the 2 meter waves ($\omega = 0.55$ rad/s), the RAO of the pitch motion was reduced from 1.44 to 1.30 (-9.7%).

In Figure 6, the RAOs of the heave motion for the vessel with and without Hull Vane are displayed.

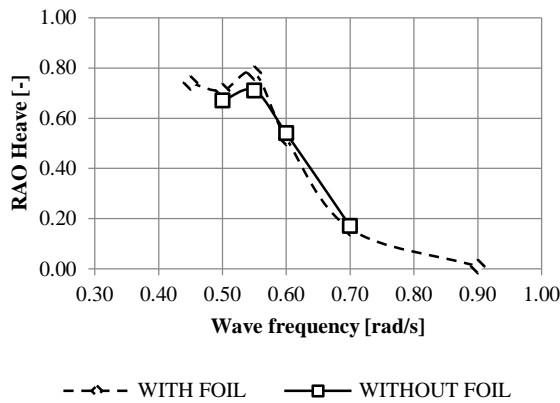

Figure 6: Heave RAO for the *Rijnborg* in waves.

The results show that the average RAO of the heave motion has increased after the Hull Vane was added to the model. The average increase is 1.6%. In the 2 meter waves ($\omega = 0.55$ rad/s), the RAO of the heave motion was increased from 0.70 to 0.71 percent (+1.4%). It can also be noted that the result is not unambiguous, as at the lower frequencies ($\omega = 0.50$ and $\omega = 0.55$) the heave has increased, while that at the higher frequencies has decreased.

In Figure 7, the required thrust is displayed for the tested wave frequencies. The thrust in flat water is also displayed for the vessel with and without Hull Vane. This value is corrected for the measured vessel speed (which varied between 19.94 and 20.25 knots). The difference between the required thrust in flat water and waves is provided as well.

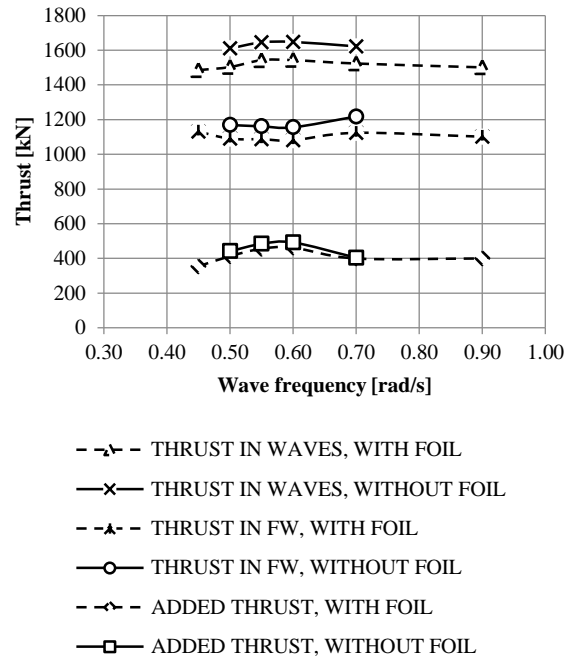

Figure 7: Thrust required in flat water, in waves, and extra thrust required due to waves for the *Rijnborg*.

The added required thrust due to waves is decreased on average by 4.9%. In the case of the 2 meter waves ($\omega = 0.55$ rad/s), the added resistance was reduced by 17.3%.

5.1.4 Tests in irregular waves

In irregular waves the vessel was only tested with Hull Vane, to investigate whether slamming would occur.

In full load conditions, slamming was not observed in 1.5m or 3.0m significant wave height. Slamming did occur in 7.0m significant wave height. In ballast conditions, slamming was observed in 3.0 meters and 7.0 meters significant wave height, for all tests except in beam waves and at high speed in stern quartering seas (20 knots).

5.2 CFD COMPUTATIONS ON THE 167m ROPAX VESSEL NORBANK

The 167m RoPax vessel *Norbank* has been tested in regular 2.5m waves with a 6.28s encounter period ($V = 20$ knots). The vessels' resulting pitch motions over one wave cycle are displayed in Figure 8.

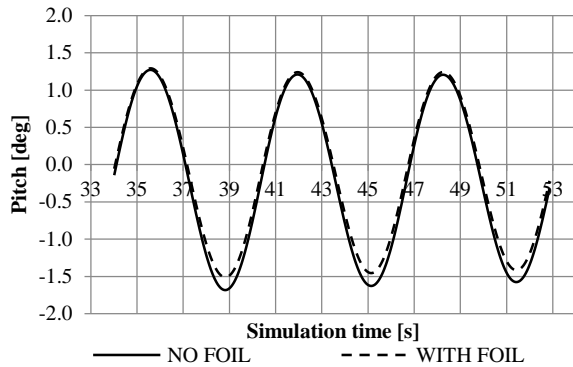

Figure 8: Pitch signal for the *Norbank* in 2.5m waves ($\omega_e = 1.00$ rad/s).

With the addition of the foil, the amplitude of the pitch motion has been reduced from 2.86 to 2.72 (i.e. the RAO has been reduced from 1.14 to 1.09). This is a 4.9% reduction.

The signal for the heave motion is displayed in Figure 9, for both the vessel with and without Hull Vane.

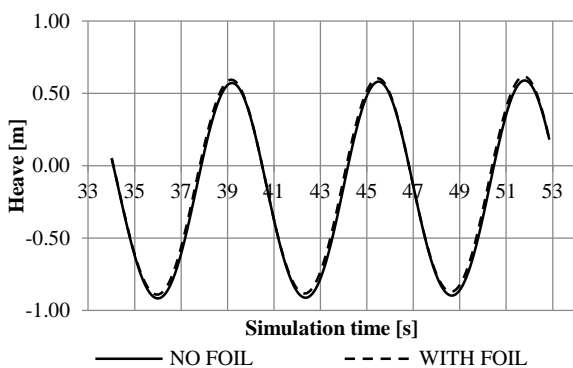

Figure 9: Heave signal for the *Norbank* in 2.5m waves ($\omega_e = 1.00$ rad/s).

The amplitude of the heave motion has decreased from 1.488 meter to 1.485 meter, which is a reduction of 0.2%.

The signal for the resistance over the same cycle is displayed in Figure 10. The flat water resistance is also shown in this graph.

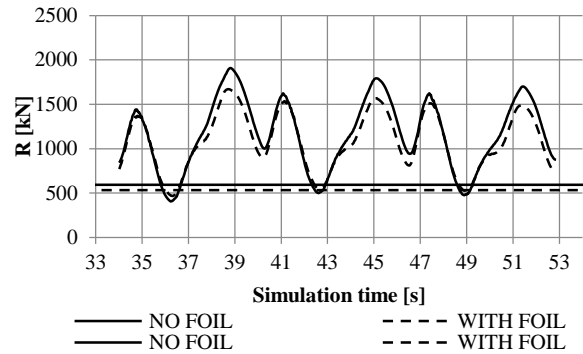

Figure 10: Resistance signal for the *Norbank* in 2.5m waves ($\omega_e = 1.00$ rad/s) and in flat water.

For the vessel without Hull Vane, the average resistance is 1169 kN, while the flat water resistance was 593 kN. The added resistance is thus found to be 576 kN. For the vessel with Hull Vane, the average resistance in this wave condition is 1083 kN. As the flat water resistance was found to be 532 kN, the added resistance due to waves is 550 kN, which is a 4.46% reduction relative to the vessel without Hull Vane.

6. DISCUSSION

The decay tests show that the addition of the Hull Vane dampens both the pitch and roll motion. The damping of the roll motion during the roll decay test was 17.9% higher. Because the absolute value for the damping is small (-0.0368 without Hull Vane, -0.0434 with Hull Vane), the influence on the natural pitch period is negligible. The natural pitch frequency is decreased from 0.88 rad/s to 0.83 rad/s, indicating that the damping of the system has increased.

The seakeeping results in regular waves underline this result. The amplitude of the pitch motion has decreased for all tested wave characteristics, during tank tests and during the CFD computations. This is in line with previous research done on smaller ships, although the percentage reduction is less on these bigger vessels. For the 167m vessels *Rijnborg* and *Norbank*, the pitch RAO was reduced by an average 4.9%, while for smaller ships reductions up to 20% were found.

The Hull Vane does not seem to have an unambiguous influence on the heave motion. For the *Rijnborg*, the RAO of the heave motion was increased by 1.6% on average, and that of the *Norbank* is decreased by 0.2% for one wave condition. However, the tank tests on the *Rijnborg* showed that the influence of the Hull Vane on the heave motion was different for different wave frequencies. It seems that the phase shift between the pitch and heave motion has an influence on the motion: if the vessel pitches bow-up, the angle of attack on to the Hull

Vane increases, and the vertical force from the Hull Vane increases. If the vessel is heaving upward at that time, this motion is intensified by the force from the Hull Vane. If the vessel were to be heaving downward at that moment, this motion would be dampened. The influence of the Hull Vane on the heave is therefore much more dependent on the wave frequency, and the resulting phase shift between the pitch and heave motion.

It must be noted that on this size of vessels, the trim has a large influence on the accelerations on board. For instance, on the *Norbank* the vertical motion in the wheelhouse due to pitching in the tested condition has an amplitude of over 3 meter, while the vertical motion due to heave was found to be 1.506 meter. Reducing the pitch motion thus significantly improves the operability of the vessel as well as the comfort for crew and passengers.

Similar to the pitch RAO, the added resistance from waves is reduced in all tested conditions on both vessels. It seems that reducing the pitch motions effectively reduces the resistance due to waves, as there is a clear correlation between the reduction of the pitch motion and the reduction of the added resistance.

Slamming on the Hull Vane occurred during the tank tests on the *Rijnborg* in ballast condition. In this condition, the Hull Vane is positioned above the static waterline. However, for ferries and RoPax vessels, the difference between the loading conditions is less than for the *Rijnborg*, which is a container vessel. For ferries and RoPax vessels, the Hull Vane would be under the waterline, significantly reducing the probability of slamming.

7. CONCLUSION

Both the tank tests and the CFD calculations show that the Hull Vane effectively reduces the pitch motion of the large 167 meter vessels and the resulting added resistance. This is in line with previous work done on smaller ships. The effect of the Hull Vane on the heave motion is not unambiguous; there is a dependency on the wave frequency and the resulting phase shift between the heave and pitch motion.

Especially for passenger carrying vessels, such as Ferries, RoPax vessels, and cruise ships, the operability and comfort for crew and passengers is of uttermost importance. The Hull Vane not only effectively improves the seakeeping performance of the vessel; it also significantly reduces the (added) resistance of the vessel. With resistance reductions up to 10% for ferries and RoPax vessels, the Hull Vane will pay back for itself over time.

8. LITERATURE

- [1] K. UITHOF, P. VAN OOSSANEN, N. MOERKE, P.G. VAN OOSSANEN, and K.S. ZAAIJER, 'An update on the development of the Hull Vane', 9th International Conference on High-Performance Marine Vehicles (HIPER), Athens, 2004.
- [2] B. BOUCKAERT, K. UITHOF, P.G. VAN OOSSANEN, and N. MOERKE, 'Hull Vane on Holland-Class OPVs – A CFD Analysis of the Effects on Seakeeping'. 13th International Naval Engineering Conference and Exhibition (INEC), Bristol, 2016.
- [3] H. HOGGEN and F.E. LUMB, 'Ocean Wave Statistics', HMSO, London, UK, 1967.

Kasper Uithof works as a project manager at Hull Vane BV. He is responsible for the design and engineering of the Hull Vanes, as well as R&D and project planning. Kasper holds a MSc in Maritime Technology from Delft University of Technology (with distinction), and a MSc in Management from the Rotterdam School of Management.

Bruno Boukaert is the commercial director of Hull Vane BV. Before he became involved with the Hull Vane, he has worked as a class surveyor in cruise ship construction and as an independent naval architect. Bruno holds a Master's degree in Naval Architecture from the University of Ghent (Belgium).

Perry van Oossanen

Niels Moerke